

Corcraft
PRODUCTS

SHELVING

- OPEN TYPE
- CLOSED TYPE
- LEDGE TYPE
- LIGHTWEIGHT COMMERCIAL

METAL



SHELVING/METAL/ Storage



NYS
DEPARTMENT
OF
CORRECTIONAL
SERVICES

SHELVING

OPEN TYPE

CLOSED TYPE

LEDGE TYPE

METAL

Corcraft

maintains an inventory of our more popular size shelving. For availability and colors, please contact our Customer Service Unit at (800) 436-6321, extension 2620, or (518) 436-6321, extension 2620.



FEATURES

Exterior Frame

- Cold rolled steel formed and bolted.
- Construction geared for heavy/industrial usage.
- 1/8" steel bracing strips used to reinforce open type shelving.
- Closed shelving units utilize 22-gauge steel for sides and back.

Shelves

- Cold rolled steel and bolted within open and closed units.
- Heavy 12-gauge steel is utilized in all shelving models to reinforce shelf of 18 gauge.
- Shelves 42" and wider include box bracing for added strength and stability.
- Seven shelves standard on each unit.
- Shelves adjustable in 1 1/2" increments.
- Each shelf rated capacity of 500 pounds, evenly distributed.

INDUSTRIAL SHELVING STEEL CONSTRUCTION OPEN TYPE

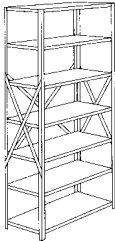
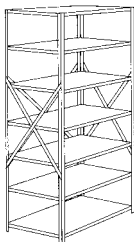
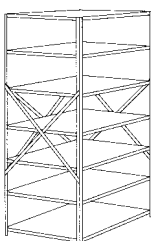
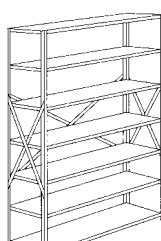
	Knocked Down	Preassembled
	F52-6336AK- * * 36W X 9D X 84H Weight 81 lb	F52-6336AS- * * 36W X 9D X 84H Weight 81 lb
	F52-6336BK- * * 36W X 12D X 84H Weight 88 lb	F52-6336BS- * * 36W X 12D X 84H Weight 88 lb
	F52-6336CK- * * 36W X 16D X 84H Weight 108 lb	F52-6336CS- * * 36W X 16D X 84H Weight 108 lb
	F52-6336DK- * * 36W X 18D X 84H Weight 117 lb	F52-6336DS- * * 36W X 18D X 84H Weight 117 lb
	F52-6336EK- * * 36W X 20D X 84H Weight 124 lb	F52-6336ES- * * 36W X 20D X 84H Weight 124 lb
	F52-6336FK- * * 36W X 24D X 84H Weight 135 lb	F52-6336FS- * * 36W X 24D X 84H Weight 135 lb
	F52-6336GK- * * 36W X 27D X 84H Weight 144 lb	F52-6336GS- * * 36W X 27D X 84H Weight 144lb
	F52-6336HK- * * 36W X 30D X 84H Weight 148 lb	F52-6336HS- * * 36W X 30D X 84H Weight 148 lb
	F52-6336IK- * * 36W X 36D X 84H Weight 179 lb	F52-6336IS- * * 36W X 36D X 84H Weight 179 lb
	F52-6328BK- * * † 42W X 18D X 84H Weight 180 lb	F52-6328BS- * * † 42W X 18D X 84H Weight 180 lb

†Ideal size for record storage.

Corcraft is your NYS preferred source vendor — place your order today!

Assembly

- Products are available in **knocked down** fashion or **preassembled at the factory**.

If you require installation (i.e. bolting together, to floor or walls) or assembly of knocked down units, please include the installation charge and code below. The charge is a per unit charge.

Installation Code A99999910 Installation Charge Per Unit—\$25.00

Delivery Problems

Products over 250 lb and/or products that equal or exceed 96 inches in any direction (conference tables, preassembled shelving, etc.) can present special delivery problems, especially if passenger elevators are involved. Often they do not fit on passenger elevators and may require that a crew use stairs. If this is the case, it must be noted on the purchase order and resolved before entering the Corcraft order.

INDUSTRIAL SHELVING STEEL CONSTRUCTION CLOSED TYPE

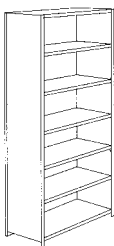

Knocked Down

F52-6338AK- * *
36W X 9D X 84H
Weight 119 lb

F52-6338BK- * *
36W X 12D X 84H
Weight 130 lb

F52-6338CK- * *
36W X 16D X 84H
Weight 152 lb

F52-6338DK- * *
36W X 18D X 84H
Weight 163 lb

F52-6338EK- * *
36W X 20D X 84H
Weight 174 lb

F52-6338FK- * *
36W X 24D X 84H
Weight 193 lb

F52-6338GK- * *
36W X 27D X 84H
Weight 202 lb

F52-6338HK- * *
36W X 30D X 84H
Weight 214 lb

F52-6338IK- * *
36W X 36D X 84H
Weight 257 lb

Preassembled

F52-6338AS- * *
36W X 9D X 84H
Weight 119 lb

F52-6338BS- * *
36W X 12D X 84H
Weight 130 lb

F52-6338CS- * *
36W X 16D X 84H
Weight 152 lb

F52-6338DS- * *
36W X 18D X 84H
Weight 163 lb

F52-6338ES- * *
36W X 20D X 84H
Weight 174 lb

F52-6338FS- * *
36W X 24D X 84H
Weight 193 lb

F52-6338GS- * *
36W X 27D X 84H
Weight 202 lb

F52-6338HS- * *
36W X 30D X 84H
Weight 214 lb

F52-6338IS- * *
36W X 36D X 84H
Weight 257 lb

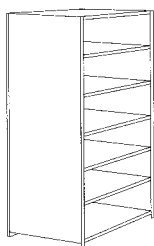

LEDGE TYPE SHELVING STEEL CONSTRUCTION OPEN TYPE

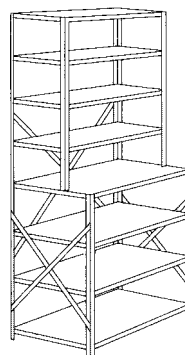

Knocked Down

F52-6346AK- * *
24W X 24-30D X 84H
Weight 145 lb

Preassembled

F52-6346AS- * *
24W X 24-30D X 84H
Weight 145 lb

LEDGE TYPE SHELVING STEEL CONSTRUCTION CLOSED TYPE

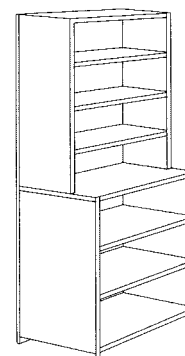

Knocked Down

F52-6363BK- * *
24W X 16-27D X 84H
Weight 195 lb

F52-6363CK- * *
24W X 16-30D X 84H
Weight 195 lb

F52-6379AK- * *
36W X 24-30D X 84H
Weight 205 lb

Preassembled

F52-6363BS- * *
24W X 16-27D X 84H
Weight 195 lb

F52-6363CS- * *
24W X 16-30D X 84H
Weight 195 lb

F52-6379AS- * *
36W X 24-30D X 84H
Weight 205 lb

Finish:

Baked Enamel standard paint colors available

Black.....	11
Grey	12
Ultra Tan	16
Driftwood Tan	19
Putty	21
Surf Green	24
Ceylon Blue	49

** Complete the code indicating your Corcraft paint color choice by including the data in the spaces provided to the right of the item code.

SHELVING

METAL

LIGHTWEIGHT COMMERCIAL

Responding to the needs
of our customers,
we have developed a
lightweight version of our
industrial shelving line.

Corcraft is pleased to
announce that we are now
accepting orders for our
lightweight commercial
shelving.

LIGHTWEIGHT COMMERCIAL SHELVING

FEATURES

Specifications

- Open design—no sides or back walls.
- 16 gauge cold rolled steel uprights.
- 18 gauge steel shelves.
- 11 gauge cross braces for strength (1/8" thick).
- Each shelf is rated for 250 lb load bearing capability.
- Seven standard colors to choose from.
- 5 shelves per unit are adjustable in 1 1/2" increments.

Sizes

- Two standard sizes—Available either fully assembled or knocked down for onsite construction. 18 x 36 x 75, 18 x 42 x 75

If you require installation (i.e. bolting together, to floor or walls) or assembly of knocked down units, please include the installation charge and code below. The charge is a per unit charge.

Installation Code A999999I0 Installation Charge Per Unit—\$25.00

Knocked Down

F52-LW1836DK- * *
36W X 18D X 75H
Weight 57 lb

F52-LW1842BK- * *
42W X 18D X 75H
Weight 64 lb

Set Up

F52-LW1836DS- * *
36W X 18D X 75H
Weight 57 lb

F52-LW1842BS- * *
42W X 18D X 75H
Weight 64 lb

Finish: Baked Enamel standard paint colors available

Black.....11	Putty.....21
Grey.....12	Surf Green24
Ultra Tan.....16	Ceylon Blue49
Driftwood Tan.....19	

** Complete the code indicating your Corcraft paint color choice by including the data in the spaces provided to the right of the item code.

Corcraft is your NYS preferred source vendor — place your order today!

All Corcraft customers can get assistance from a Corcraft sales representative. They provide detailed information on the more than 300 Corcraft products and can help in selecting the best solution and in placing orders. If you have not been contacted by Corcraft, please call our Customer Service Unit listed to the right. To place an order directly to our headquarters, FAX or mail your purchase order using the contact information at the right. ***If you FAX your purchase order, please do not mail a duplicate.***



NYS DEPARTMENT OF CORRECTIONAL SERVICES DIVISION OF INDUSTRIES

550 Broadway
Albany, New York 12204-2802

Order Services Mail to above address
Order Services FAX (800) 898-5895 or (518) 436-6007
Customer Service Voice (800) 436-6321 ext. 2620
(518) 436-6321 ext. 2620
Web <http://www.corcraft.org/>

Corcraft accepts the American Express® Corporate Purchasing Card.